

# HRG15\*\*S1R

## SPECIFICATIONS

### Compressor

- High-efficiency scroll compressor
- R410A refrigerant
- Grommet-mounted compressor for quiet operation
- Heavy-duty compressor sound blanket for quiet operation (optional accessory)
- Internally protected against high temperature motor overload conditions

### Cabinet

- Full metal louvered construction to protect the coil
- Corner-mounted controls for easy service
- Baked polyester paint finished over galvanized steel for maximum durability
- External gauge ports for easy service
- Removable service panel for internal access

### Design

- Designed to perform in temperatures up to 125°F
- Designed to perform in temperatures down to 0°F

### Coils

- Total corrosion protection technology designed coil
- Enhanced tube-and-fin coil design
- Lanced fins for maximum heat transfer
- Factory tested for leakproof construction
- Raised coil prevents debris from impeding airflow

### Components

- Factory installed high and low pressure switches
- Thread-on pressure switches for simple, quick service
- Factory installed filter dryer
- Fan orifice for smoother airflow and sound level reduction
- Charged for 15 feet of line set
- Discharge muffler for quiet operation
- Reduced noise during defrost

The Century logo features the word "Century" in a bold, green, sans-serif font. To the left of the text is a stylized graphic of three curved lines in yellow, orange, and blue, suggesting a sun or a flame.

## SPLIT SYSTEM HEAT PUMP

*15 SEER High Efficiency  
Up to 18.2 SEER & 10.6 HSPF  
Up to 16.9 SEER2 & 9 HSPF2*



For the latest AHRI system matches,  
please visit [www.marsdeliversratings.com](http://www.marsdeliversratings.com)  
or [AHRIDirectory.org](http://AHRIDirectory.org)

**Warranty**—12 years on compressor, 6 years on parts  
(Some limitations apply; see printed warranty for details.)

[www.marsdelivers.com](http://www.marsdelivers.com)

## MODEL NUMBER GUIDE

<b>H</b>	<b>R</b>	<b>G</b>	<b>15</b>	<b>24</b>	<b>S</b>	<b>1</b>	<b>R</b>
Heat Pump	Residential Split	'Green' Gas	SEER 15	Capacity	Scroll Compressor	Power 1 = 208/230-1-60	Series/ Revision

## ELECTRICAL AND PHYSICAL DATA

Model	Voltage/Hz/Phase	Voltage Range	Min. Circuit Amp.	Max. Over Current Device (amps)	Compressor		Outdoor Fan Motor		
					Rated Load (Amps)	Locked Rotor (Amps)	Full Load (Amps)	Rated HP	Nom. RPM
HRG1518S1R	208-230/60/1	197-253	13.6	20	10.3	45.7	0.7	1/8	825
HRG1524S1R	208-230/60/1	197-253	15.1	25	11.5	59.5	0.7	1/8	825
HRG1530S1R	208-230/60/1	197-253	15.6	25	11.7	71.3	1.0	1/6	825
HRG1536S1R	208-230/60/1	197-253	17.8	30	13.1	83.1	1.4	1/5	825
HRG1542S1R	208-230/60/1	197-253	25.9	40	18.6	110.0	2.6	1/3	825
HRG1548S1R	208-230/60/1	197-253	33.9	50	25.0	120.0	2.6	1/3	825
HRG1560S1R	208-230/60/1	197-253	32.5	50	23.9	124.5	2.6	1/3	825

## DIMENSIONS (IN.)

Model No.	Dimensions (inch)			Shipping Weight (lbs.)
	A - Width	B - Depth	C - Height	
HRG1518S1R	28.25	28.25	43	185
HRG1524S1R	28.25	28.25	43	185
HRG1530S1R	28.25	28.25	33	185
HRG1536S1R	32.25	32.25	33	220
HRG1542S1R	32.25	32.25	38	250
HRG1548S1R	32.25	32.25	38	250
HRG1560S1R	32.25	32.25	43	260

Note:  
Dimensions listed are unit sizes w/o packaging  
Weights listed are unit weights with packaging

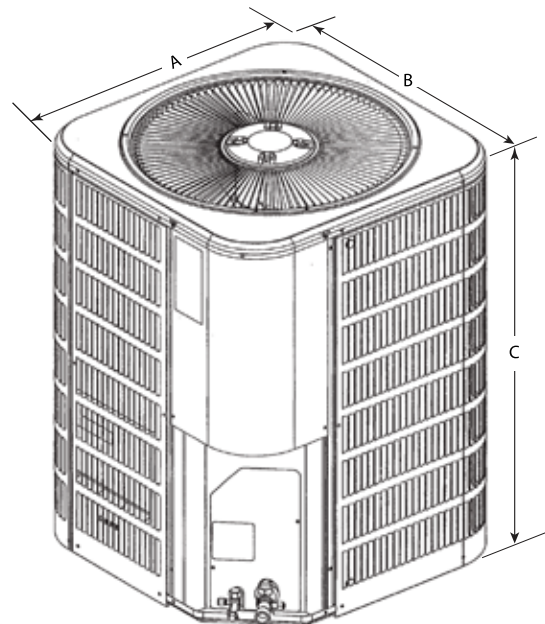

### NOTE:

For the latest AHRI system matches, please visit  
[www.marsdeliversratings.com](http://www.marsdeliversratings.com) or [www.AHRIdirectory.org](http://www.AHRIdirectory.org)

## SOUND RATINGS

Model	Sound Power <sup>1</sup>	Estimated Sound Pressure (dBA) <sup>2</sup>		
		Approximate Distance <sup>3</sup>		
		One Meter (3.3 feet)	Two Meters (6.6 feet)	Three Meters (9.8 feet)
HRG1518S1R	74	66	60	56
HRG1524S1R	74	66	60	56
HRG1530S1R	74	66	60	56
HRG1536S1R	75	67	61	57
HRG1542S1R	78	70	64	60
HRG1548S1R	79	71	65	61
HRG1560S1R	79	71	65	61

<sup>1</sup> Rated in accordance with AHRI standard 270 (2015)

<sup>2</sup> Rated in accordance with AHRI standard 275 (2010)

<sup>3</sup> Based only on distance factor; other factors may change this value such as:

- Unit location (reflective surfaces adjacent to the unit)
- Barrier shielding sources
- Sound path/elevation
- Outside noise sources

## REFRIGERATION DATA

Model	Factory Refrig. Charge (oz.) *	TXV	Refrigerant Line Size		Outdoor Unit Connection		Indoor Unit Connection	
			Suction	Liquid	Suction	Liquid	Suction	Liquid
HRG1518S1R	98	H4TXV01	3/4	3/8	3/4	3/8	3/4	3/8
HRG1524S1R	96	H4TXV01	3/4	3/8	3/4	3/8	3/4	3/8
HRG1530S1R	117	H4TXV01	3/4	3/8	3/4	3/8	3/4	3/8
HRG1536S1R	137	H4TXV02	7/8	3/8	7/8	3/8	7/8	3/8
HRG1542S1R	162	H4TXV02	7/8	3/8	7/8	3/8	7/8	3/8
HRG1548S1R	146	H4TXV02	7/8	3/8	7/8	3/8	7/8	3/8
HRG1560S1R	164	H4TXV03	1-1/8	3/8	1-1/8	3/8	1-1/8	3/8

\* Factory charged for 15 feet of line set; adjust per installation instructions  
Reducer fitting supplied with OD unit

## COOLING PERFORMANCE WITH AIR HANDLERS

Outdoor Model	Indoor Model	Cooling						Heating						
		Evap. Coil or Air Handler <sup>3</sup>	SEER	SEER2	EER	EER2	AHRI Rated Capacity <sup>1</sup>	Sensible Capacity	HSPF	HSPF2	47°		17°	
											Btuh	COP	Btuh	COP
HRG1518S1R	HMG24X1M	15.5	14.7	13.0	12.4	23200	17800	9.6	8.0	22200	3.72	14000	2.54	
HRG1524S1R	HMG24X1M	15.5	14.7	13.0	12.4	23200	17800	9.6	8.0	22200	3.72	14000	2.54	
HRG1530S1R	HMG30X1M	15.0	14.4	12.2	12.0	28400	22400	9.2	8.0	27800	3.56	18000	2.52	
HRG1536S1R	HMG36X1M	15.5	14.7	12.5	12.4	35600	27000	9.6	8.0	34000	3.62	22400	2.56	
HRG1542S1R	HMG42X1M	15.0	14.4	12.2	12.0	40500	30800	9.2	7.8	39000	3.40	25000	2.46	
HRG1548S1R	HMG48X1M	15.4	14.7	12.5	12.4	47000	35400	9.8	8.2	46500	3.64	30400	2.64	
HRG1560S1R	HMG60X1M	15.1	14.3	12.5	11.7	56500	41500	9.6	8.0	54000	3.50	35000	2.56	

Note:

<sup>1</sup> Required to achieve AHRI rating. If NA (not applicable) is in the piston column then TXV is required.

<sup>2</sup> Certified in accordance with Unitary Air Conditioner Certification Program, which is based on AHRI Standard 210/240

<sup>3</sup> A blower time delay relay is standard on all Comfort-Aire/Century furnaces and air handler products

## ACCESSORIES

Description	Where Used	Kit Number	Purpose
Liquid Line Solenoid	All models	60M52	Prevents liquid migration to the compressor especially for high liquid riser applications
Low Ambient (cooling operation)	All models	54M89	Enables cooling demand down to 30 °F. Will require freeze stat, CC heater and TXV
Mild Ambient (heating operation)	All models	11B97	Enables heating demand above 60 °F ambient
Cold Weather	All models	1.921145	To allow unit to operate at very low ambient conditions (older models). Board integrated feature on new models
Fossil Fuel Kit (Heat Pump Only)	All models	1.841185 (AFOSL500)	Required for furnace with heat pump installations
Hard Start	24 & 36	10J42	Scroll compressors usually do not require hard start; maybe needed for utility brown-out or low voltage areas
	48 & 60	81J69	
Crankcase Heater	18, 24, 30	93M04	Prevents liquid migration to compressor in cold weather
	36, 42, 48, 60	Factory Installed	
Sound Cover	18, 24, 30, 36	14W00	Lowers compressor sound level
	42, 48, 60	14W01	
Loss of Charge Kit	Factory Installed		Protects the compressor if refrigerant charge is too low
<b>Additional System Accessories (indoor section)</b>			
TXV Kit	18, 24, 30	H4TXV01	TXVs provide superior refrigerant flow control, comfort and efficiency compared to pistons
	36, 42, 48	H4TXV02	
	60	H4TXV03	
Outdoor Thermostat - Electric Heat	All models	10Z23 (56A87)	Prevents electric heat operation above specific ambient conditions
Outdoor Thermostat - Mounting Box	All models	31461	Mounting box for outdoor thermostat
Freezestat	All models	93G35	Protects the compressor at low suction pressure conditions
Overflow switch	All models	11U75	Turn the system off, if condensate water overflows due to clogged drain pipes
Single Point Power Supply	All models	21H39	Provide single power source in one junction box
Auxiliary Blower Relay	All models	85W66	Maybe required to select multiple indoor blower speeds

"This product complies with all California product labeling laws including, but not limited to, the Safe Drinking Water and Toxic Enforcement Act of 1986, more commonly known as Proposition 65."

*Due to ongoing product improvements, specifications and dimensions are subject to change and correction without notice or incurring obligations. Determining the application and suitability for use of any product is the responsibility of the installer. Additionally, the installer is responsible for verifying dimensional data on the actual product prior to beginning any installation preparations.*

*Third party incentive and rebate programs have precise requirements as to product performance and certification. All products meet applicable regulations in effect on date of manufacture; however, certifications are not necessarily granted for the life of a product. Therefore, it is the responsibility of the applicant to determine whether a specific model qualifies for these incentive/rebate programs.*